

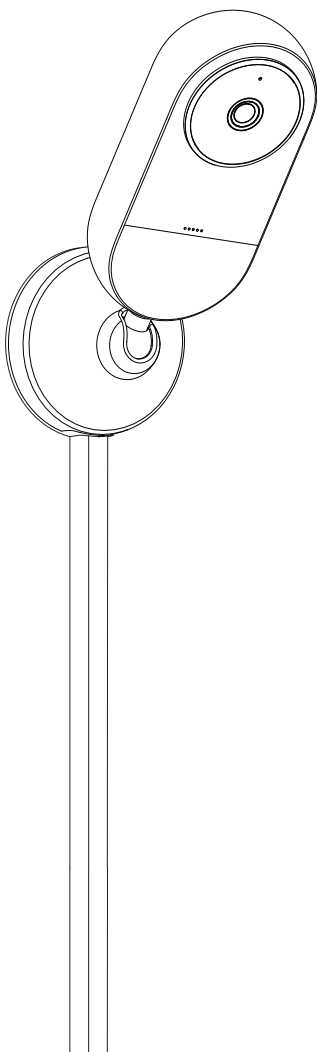

Cheego

Smart Baby Monitor

X3 Pro / User Guide



WHAT'S IN THE BOX

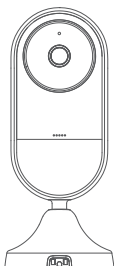

Cheego Monitor
x 1



Cable Covers
x 6

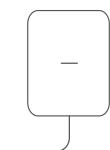

Power Adapter
x 1

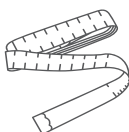

Mounting Template
x 1

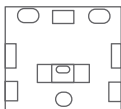

Mounting Bracket & Level
x 1



Self Drilling Drywall Anchors
x 3



Drywall Anchors
x 3



Screws
x 3



User Guide
x 1

PRODUCT OVERVIEW

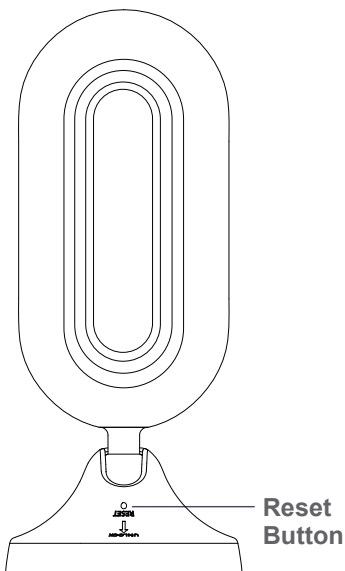
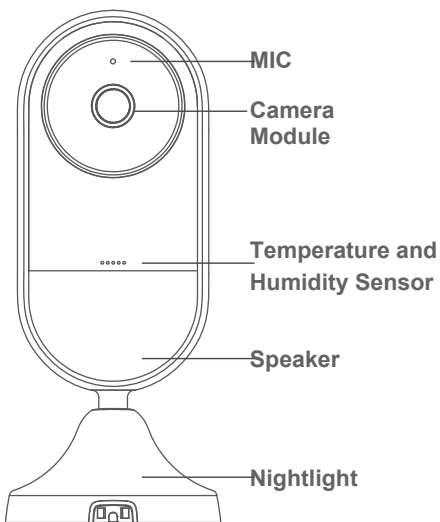

SAFETY

⚠ Strangulation Hazard—Children have STRANGLED in cords. NEVER attempt to use cord without the protective covering. Check protective covering before each use to ensure that the cord is not exposed to your child. Immediately discontinue use if protective covering is damaged or broken.

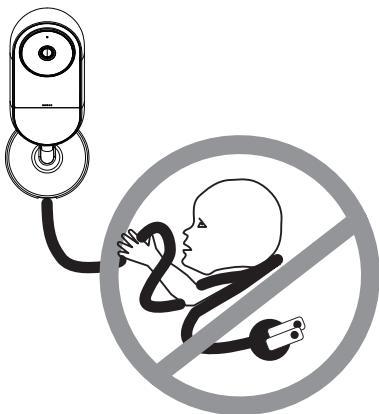

- This device is designed to be mounted behind a standard crib and against the wall.
- Adult assembly is required. Keep small parts away from children when assembling.
- This product cannot replace adult supervision. Ensure your baby's health by checking on him/her regularly.
- This device is designed for indoor use only.
- This product and its packaging are not intended for use as toys. Please do not allow children to play with them.
- Falling warning: To prevent the product from falling and causing injury, make sure to install the monitor in a stable location, tighten the screws securely, and monitor your device.
- Make sure the monitor could capture the baby's facial image clearly after the installation.

INSTALLATION

Position your crib against the wall where you will mount the Cheego Monitor. Ensure that there are no studs in the center of the crib and that the power outlet is out of your child's reach.

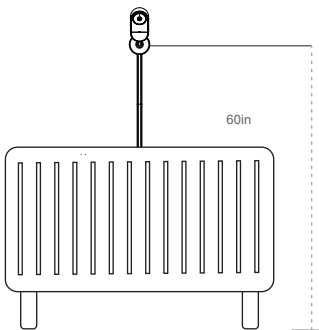

1. Using the included Mounting Template, find the center of the crib and mark it (as ①) on your wall.

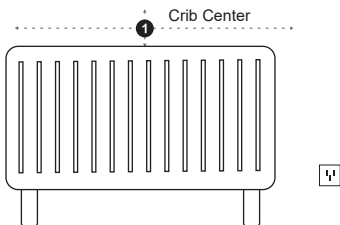

2. Pull straight and vertical the Mounting Template, then align with the mark ①. Once in position, make a mark on your wall at 60" (as ②).

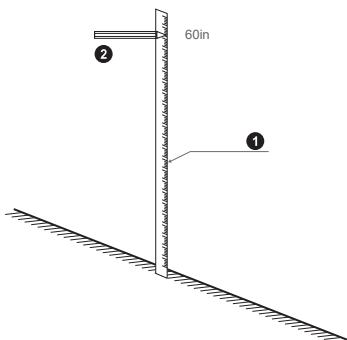

3. Align the screw holes at the lowest part of the mounting bracket (mark ②) then adjust it using the built-in level. Once level, mark the wall through the two top holes in the bracket (as ③④).

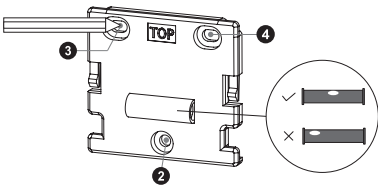

4. Drill 1/4" holes in the three marked spots (②③④).

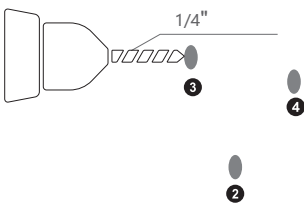

5. Insert three anchors until flush with the wall.

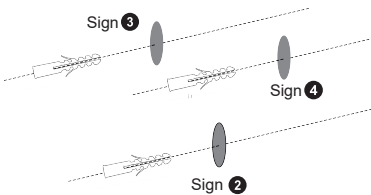

6. Align the mounting bracket with the three anchors, and insert screws into the anchors and screw in halfway.

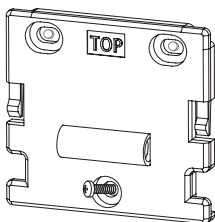

7. Adjust the Mounting Bracket using the built-in level. Once level, tighten the three screws.

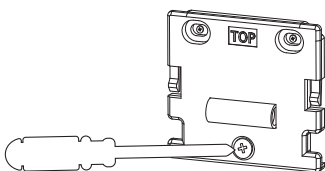

8. Place Cheego monitor over Mounting Bracket and press it down until it clicks.

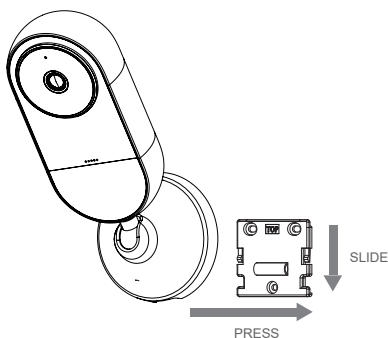

9. Organize the power cable, peel the tape backing off the Cable Covers, and firmly adhere the bottom of the cable covers to the wall. Connect the power cable with the DC Power Adapter, plug the power adapter into your outlet. Make sure that the power outlet you use is not within your child's reach.

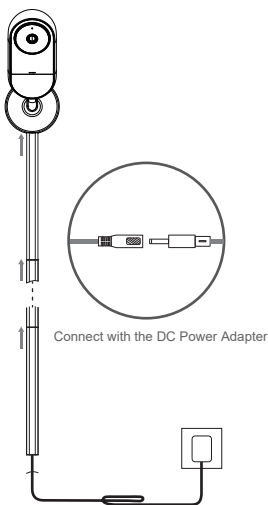

Organize the extra power cables with velcro.

INSTRUCTIONS

Get start with the Cheego Smart App

Download the Cheego Smart App from Apple Store/Google Play or scan the QR code in the user guide.



Download & Register
"Cheego Smart" APP

Set up your account and follow the in-app instructions to set up your Cheego Smart monitor.

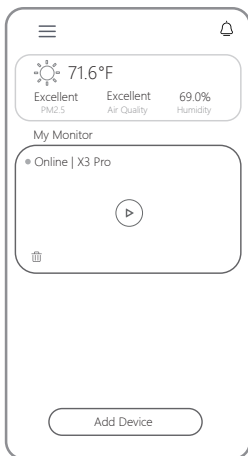

Boot

Please connect the monitor to the power adapter. Once connected, the LED light will turn on and off automatically.

Please wait about 20 seconds before the device boot up successfully.

⚠ Cheego Smart APP will upgrade and update. The actual operation may be different from the above description. Please follow the instructions in the current version.

⚠ When establishing a connection, please ensure that you have a stable network and keep the monitor powered on. Please try to use 5G WiFi for better network connection quality.

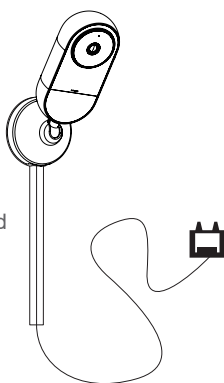

SPECIFICATIONS

Model	X3 Pro
Resolution	1296P
Lens	f=3.2mm / F1.6
Field of View	130° (Diagonal)
Connectivity	Wi-Fi 2.4GHz/5GHz
Support System	Above android 11.0 or IOS 13.0
TF card	32GB
Mounting	Wall Mount (Standard Package) Floor Stand Mount (Need to Purchase a Replacement Floor Stand)
Power	DC12V / 1A
Working Temperature	0-40°C
Dimensions	90X90X215mm
Item Weight	0.36kg

FEATURES INSTRUCTIONS

Live Video And Two-Way Audio

Cheego X3 Pro 3MP ultra HD camera and high-quality speaker provide the fantastic connection with your baby anywhere and anytime.

Crying Detection & Soothing Music

Cheego X3 Pro automatically plays soothing music, turns on the nightlight (at night), and sends alarm messages to the App when it detects the baby's crying.

Sleep Nanny

Cheego X3 Pro captures and analyzes baby's sleep with AI technology in real time, and sends notifications to the App if your baby wakes up.

Moments

Cheego X3 Pro uses an advanced algorithm to capture photos and videos of baby's wonderful moments. Record your baby's precious time.

Virtual Fence Detection

Cheego X3 Pro sends alarm messages to the App when the baby is out of the virtual fence.

Temperature and Humidity Detection

Embedded high-precision temperature and humidity sensor, Cheego X3 Pro checks the room temperature and humidity in real time to make the baby more comfortable.

Face Covering Detection

Sends alarm messages to the App when the baby's face cannot be detected.

Danger Zone Detection

Set the electronic area as the danger zone, when your baby enters the danger zone, Cheego X3 Pro provides voice warning and sends alarm messages to the App.

Non-Invasive Night Vision

Non-invasive infrared sensor makes clear vision in the dark.

Sleep Report

Monitor your baby's sleep status to generate daily and weekly summaries.

FAQ

I don't hear “received network configuration information”when I pair the monitor.

To improve the user experience, please try to use a 5GHz WiFi network whenever possible. If the quality of the 5GHz WiFi network is not good, please switch to the 2.4GHz WiFi.

What should I do if the QR code cannot be recognized?

Hold your phone screen facing the monitor, maintaining a distance of 8"-12" to avoid exposing the monitor to strong light.

What should I do if mobile phone cannot receive the notification?

Go to mobile “setting”→“Cheego Smart”→“Allow Notifications”

What should I do if the Cheego X3 Pro goes offline ?

1. Please shut down your device and then reboot it.
2. If you have changed your Wi-Fi network, please refer to the RESET instructions to reset your monitor.

How to RESET the Cheego X3 Pro?

Press and hold the RESET button on the monitor for 5 seconds, then follow the "Reset Device Step by Step" instructions in the Cheego Smart App, completing each step as directed.

What should I do if there's an echo during intercom?

During intercom, keep the mobile phone at least 30 feet away from the device to minimize echo and howling, which are normal occurrences.

GUARANTEE & WARRANTY

Satisfaction Guarantee & Return Policy

Thank you for purchasing Cheego products. If you are not completely satisfied with your purchase, you may return the product for a full refund within 30 calendar days of setting up a hardware product (icheego.com) or within 15 days of activating an online product (Cheego authorized online reseller). This satisfaction guarantee requires proof of purchase from an authorized seller. Purchases from 3rd party retailers will need to be returned to the original place of purchase.

Limited Warranty

This limited warranty contains important information about your rights and obligations, as well as limitations and exclusions that may apply to you.

This limited warranty only applies if you are the original purchaser, use and operate the product in the United States or Canada. Please note if you are not resident of the United States or Canada, this Limited Warranty & Return Policy does not apply to you.

Products obtained from unauthorized retailers are not covered by this Limited warranty.

Please be aware that there are some retailers and websites that claim to be authorized retailers of Cheego when they are not. Note that when you purchase from these unauthorized retailers, you are taking a risk, including a risk that these products are used or defective, and this limited warranty will not apply.

1.What This Limited Warranty Covers?

Period of coverage.Warrants to the owner of the enclosed product that the product contained in this box ("Product") will be free from defects in materials and workmanship for a period of one (1) year from the date of delivery following the original retail purchase (the "Warranty Period"). If you believe you have received a defective product, we will either repair or replace the defective product or its defective component part(s) in accordance with the terms of this limited warranty. We warranty replacement for the remaining unexpired period of the original product's warranty. This limited warranty is th e only warranty available for our products.

2.What This Limited Warranty Does Not Cover?

- Products labeled as "sample" or "Not for Sale" or sold "AS IS."
- Ineligible Products that have been modified, tampered with, improperly maintained or repaired, or altered in any way.
- Products that have been handled, stored, installed, tested, or used not in accordance with the Terms of Service or other instructions provided by Cheego.
- Products that have been abused or misused.
- Damages caused by Acts of God, including but not limited to lightning, flood, tornado, earthquake, or hurricane.
- Consumable parts, such as batteries, unless the damage is due to defects in materials or workmanship.
- The use of unauthorized service providers for maintenance or repair.
- Unauthorized use of the Product or software that may affect its performance.
- This limited warranty does not cover any software, even if it is packaged or sold with the Products.
- Please refer to the licensing agreement accompanying the software for details of your rights regarding its use.
- This limited warranty does not guarantee that the operation of the product will be uninterrupted or error-free.
- This warranty is non-transferable from the original end-user to others.

3. Not a Medical Device.

Cheego X3 Pro is not a medical device and is not intended for diagnosing or treating any diseases. It uses computer vision algorithms and sensing technology to assess breathing motion. It should not replace the care of adults or consultation with medical professionals.

4.Disclaimer of Warranties

Except as stated above in section 1 of this limited warranty, and to the maximum extent permitted by applicable law, cheego disclaims all express, implied, and statutory warranties and conditions with respect to the product, including the implied warranties of merchantability, fitness for a particular purpose and non-infringement. To the maximum extent permitted by applicable law, cheego also limits the duration of any applicable implied warranties or conditions to the duration of this limited warranty. For the avoidance of doubt, nothing in this clause 6 is intended to exclude any warranties or guarantees which cannot be excluded under applicable laws.

5.Your Rights and This Limited Warranty

We limit the applicability of implied warranties, including the implied warranties of merchantability and fitness for a particular purpose, to the duration of this limited warranty. To the extent permitted by law, we disclaim all other warranties of any kind. Some states and countries do not allow limitations on implied warranties, so the above limitation may not apply to you. Our sole liability for any defect shall be as set forth in this limited warranty and excludes any claims for incidental or consequential damages. Some states and countries do not allow the exclusion or limitation of incidental or consequential damages, so the above limitation or exclusion may not apply to you. No person or entity is authorized to make any other warranty on our behalf. This warranty gives you specific legal rights. You may also have other rights which vary from state to state and country to country.

COMPLIANCE



DECLARATION OF CONFORMITY

Declares that the Model X3 Pro equipment is in compliance with Part 15 of the FCC Rules and RoHS regulations.



This symbol means the product must not be discarded as household waste, and should be delivered to an appropriate collection facility for recycling. Proper disposal and recycling helps protect natural resources, human health and the environment. For more information on disposal and recycling of this product, contact your local municipality, disposal service or the shop where you bought this product.